

IF-4852FPT

Bolt-On 1974 & Up Pinto Mustang IFS for 1948-1952 Ford Pickup Truck

- 1** Remove the original front suspension. Straighten the edges and lips on the frame where the new crossmember and support rods will be placed. Make sure the frame edges are a straight 90 degrees from the side of the frame. Remove any rivet heads that might interfere with proper fitting of the crossmember. Grind these flush with the frame.
- 2** Bolt new lower crossmember to bottom of the frame using these dimensions.

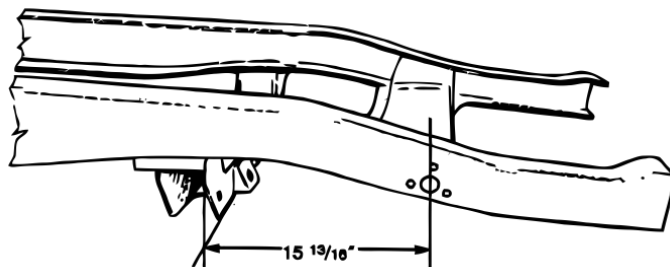

Steering mounts on crossmember go to the front. Measure from center of original front spring mount to front of new crossmember.

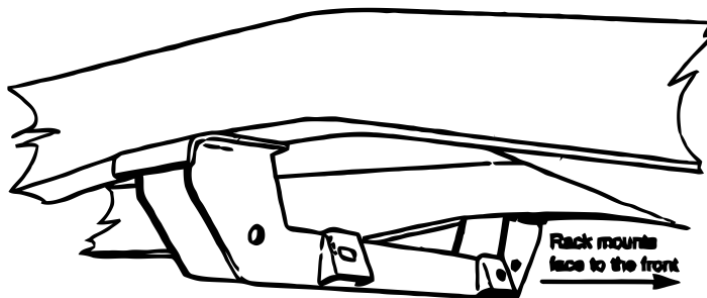

- 3** Place coil spring pods over frame and line up with lower crossmember. Pods will fit only one way (taller side to front). Check for clearances between frame and new parts. Correct any interference problems found. At this point we recommend that you check for tire centering. Do this by assembling A-arms and spindle on one side, (without a spring) and installing a wheel. Visually check for centering. In the unlikely event of a miss, the crossmember can be moved up to a 1/2 inch. Wheel centering is normally not a problem, but it is always better to check.

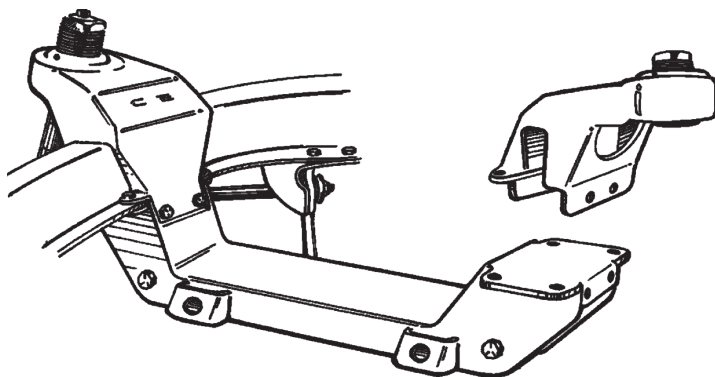

- 4** Clamp upper and lower pieces together and in place. Again, check fit. When drilling new holes, do the vertical holes first. Insert these bolts and tighten. Now drill holes in sides (8 per side), insert bolts and tighten. Crossmember, frame and pods should now be firmly attached to each other.



IF-4852FPT

5 Strut rod support brackets are next. Straighten frame edges to 90 degrees. Put bracket in place around frame and insert a bolt in the center brace to crossmember tube. Now fit the bracket to frame and locate the point where the bracket fits the frame the best. Do both sides. Compare measurements and make them both the same. Brackets will fit the frame exactly only if the frame is straight and the bottom lip of frame is 90 degrees to the side. Clamp in place.

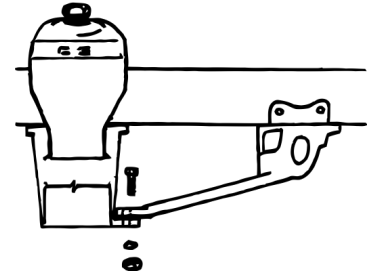

6 Drill underneath holes first, keeping brackets flush with outside of frame. Do outside holes, bolting as you go.

7 With this kit you received two rack extensions. Be sure to install them to move the tie rod inner pivot outward. Steering problems will result if they are not used. This kit is 2 inch wider than stock Pinto. These spacers are critical for correct geometry.

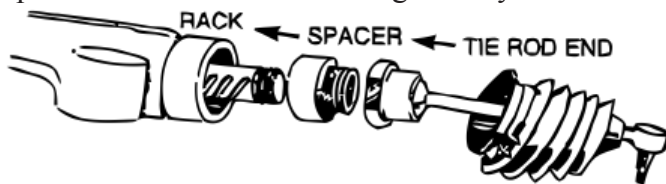

Be sure these extensions are locked to the rack and to the tie rod both. We prefer a 1/8" hole drilled halfway through the extension and the original shaft, then a roll pin driven in for a lock. But whatever

method you use be sure the extension cannot unscrew itself in use.

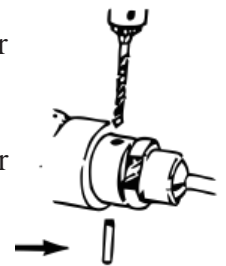

8 Install components from 1974-1980 Pinto/1974-1978 Mustang II to complete the installation. Manual steering is recommended. Use Pinto strut rods, no Mustang strut rods. Use a new strut rod bushing set. See Ford or Front-End manuals for installation instructions covering A-arm, strut rods, springs, shocks and lineup specs. Cut your coil to 12" height. (Chassis Engineering coil springs are sized properly).

9 Chassis Engineering has springs available in 25 pound increments.

10 To adjust the height, first take off all the weight off of the springs. This means jacking up the front wheels of the ground and possibly unhooking the shocks.

Caution: To prevent injury make sure to use jack stands to support the car anytime you may be working under it.

Loosen 1/4" locking set screw and turn height adjuster to new position. The

11 The final step is to have the front end aligned to Pinto specs. Once a "fresh" car with a new IFS gets some good road miles, it may become necessary to once again adjust the IFS spring pods due to normal settling of the new front coil springs. The lower control arms must maintain a "parallel to the ground" stance for good geometry and prolonged ball joint life. When making such an adjustment remember to loosen the set screw and add a little anti-seize compound before turning down the spring adjuster. Removing the shock and use of a spring compressor will also aid in this procedure. To aid in adjusting your IFS, we offer the IF-0000W adjustment wrench. Afterwards, reinstall the shock and tighten the set screw.

