

# CP-1105 ES-1150

## 1935 Chevy Standard Chevy Small Block V8 Engine Mount Kit (CP-1105)

- 1** Bolt engine mounts to the small block Chevy engine to be installed.
- 2** Install frame adapters around frame and clamp in position shown. Make sure adapters are straight and level.
- 3** Drill bolt holes in frame, install bolts and tighten.
- 4** Install cushion set as shown.

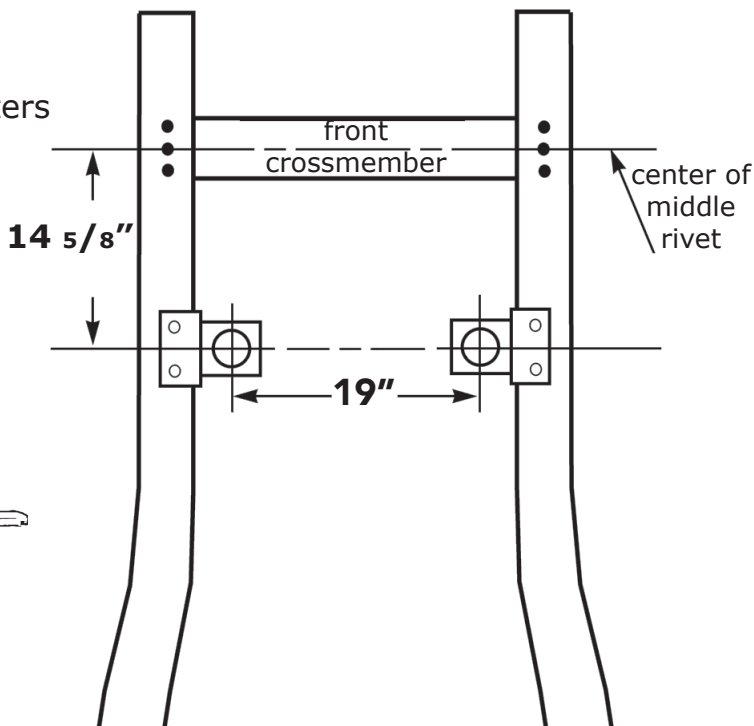
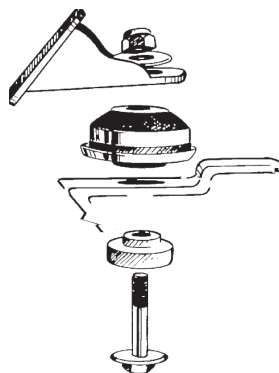

## 1935 Chevy Turbo 350 and Powerglide Transmission Mount Kit (ES-1150)

- 1** Remove original transmission support.
- 2** Line up two front holes with original crossmember holes.
- 3** Drill and bolt new transmission mount in place.

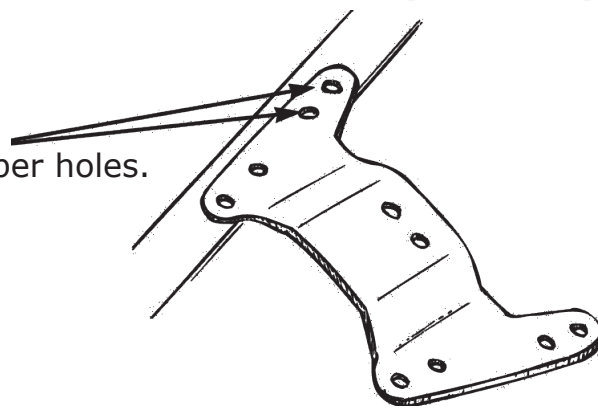

### Notes:

Original steering can be used by moving it back on the frame.

Driveshaft clearance is minimal where it passes through X-member center. When car is sitting in final position, this clearance should be checked.

Transmission can be raised for driveshaft clearance by installing spacers under rubber mount.