



CP-4143

1933 Dodge DP, 1933-35 Dodge Pickup, 1935 Plymouth PD Mopar 340-360 V8 Weld-in Engine Mount Kit

use with IFS (note: steering must be changed to use with stock solid axle)

- 1 Frame adapters mount will bolt to a flat area on the frame. If not, your frame isn't covered by this kit.
- 2 Clamp frame mounts into position as shown. Mounts should center on a flat area. Set engine in place to make sure they are positioned correctly. The flat area may or may not already have holes already. These holes come in different sizes, some slotted, and in different locations. Most are however usable as bottom mounting holes.

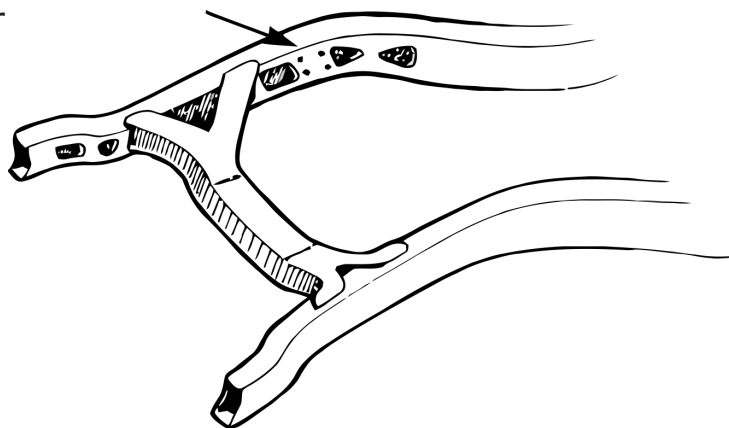
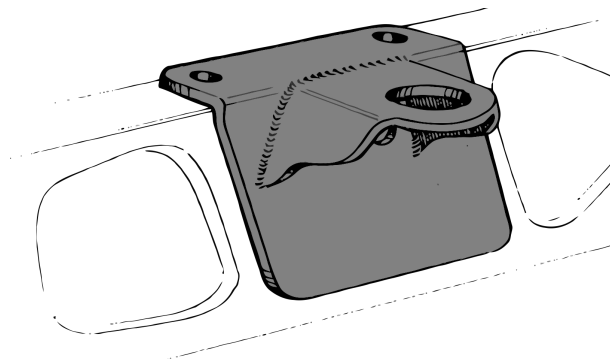

- 3 Drill top holes through flanges. To mark for drilling, reach inside the frame with a stub pencil and mark their location on the frame mount. Do this only to the bottom two holes on each side. Remove mounts and drill these holes.
- 4 Reinstall frame adapters and bolt in place. Use bolts that match hole size. Because of size differences, these bolts are **not** included with the kit.
- 5 Bolt Chassis Engineering engine mounts to the engine with offset facing forward.
- 6 Install engine using rubber cushion set. Assemble as shown.

engine mount

frame adapter

