



CP-1160G

1940-54 Chevy 1/2tn Pickup Small Block Chevy Engine Mount Kit (using weld-in Pinto Mustang IFS)

- 1** Remove original engine, transmission and steering column.
- 2** Install mounts in frame as shown. Tack-weld mounts into place and recheck fit.
- 3** Mounts can now be finish welded into place if desired.
- 4** Point type distributor or small HEI will fit. Larger distributor will need firewall modification.

Frame adapter will tilt to rear of vehicle.

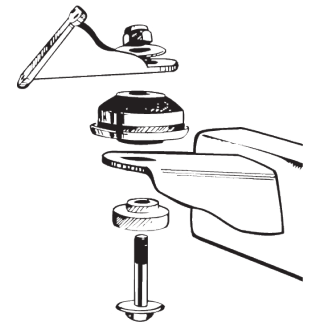
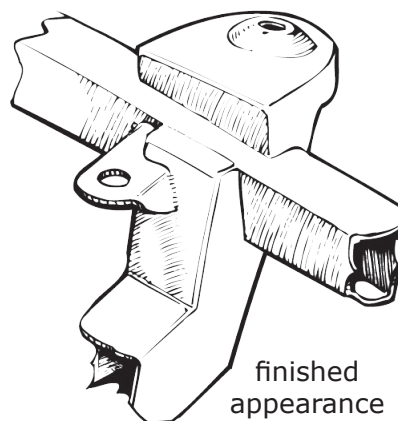
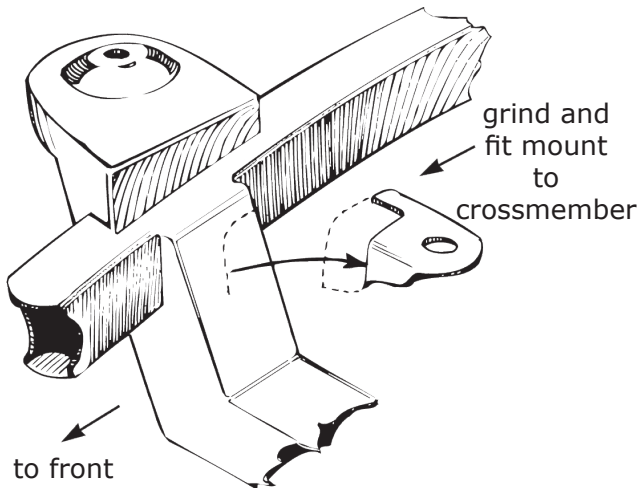
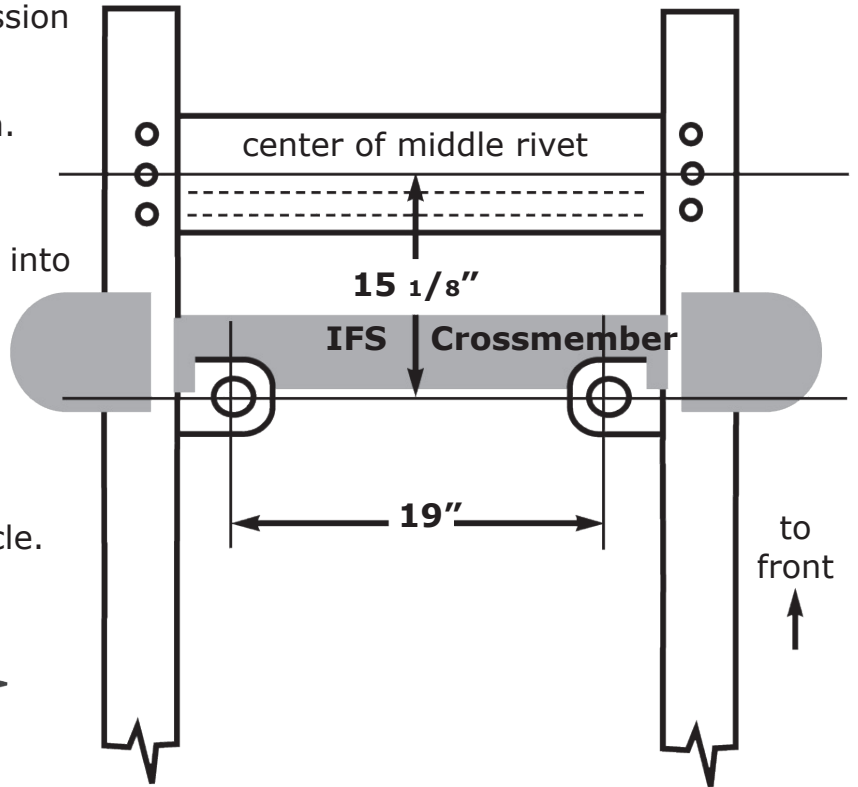
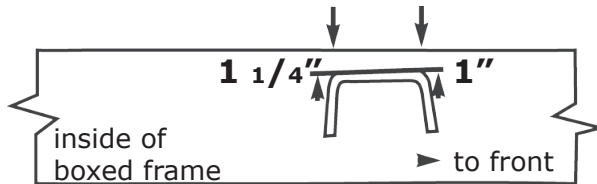

Note: Drawings represent general appearance and may differ, depending on the IFS.