



CP-2601

1935-40 Ford Car and 1/2tn Pickup Buick/Olds V6 (1961-67, 1975+) Engine Mount Kit
use with X-member modification and transmission mounting kit from Chevy V8 into 35-40 Ford Kit

1 Loosely bolt torque brackets to frame adapters.

2 Place adapters over frame and position as shown. Clamp into place and recheck dimensions. Drill for 3/8 inch bolts. Drill the two bottom holes in the same approximate location as the top holes.

3 Torque bracket will lay against front crossmember. Drill through bracket and crossmember, then bolt in place.

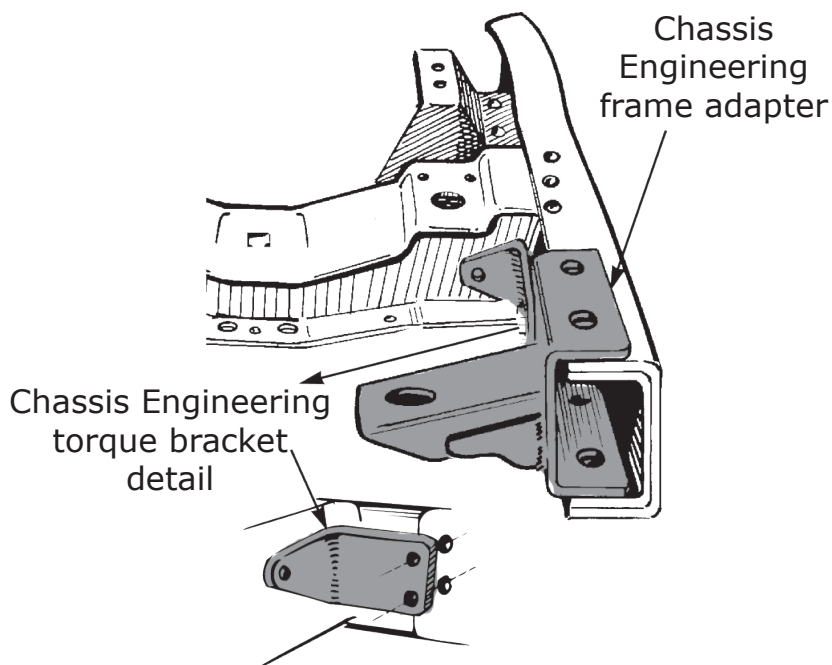
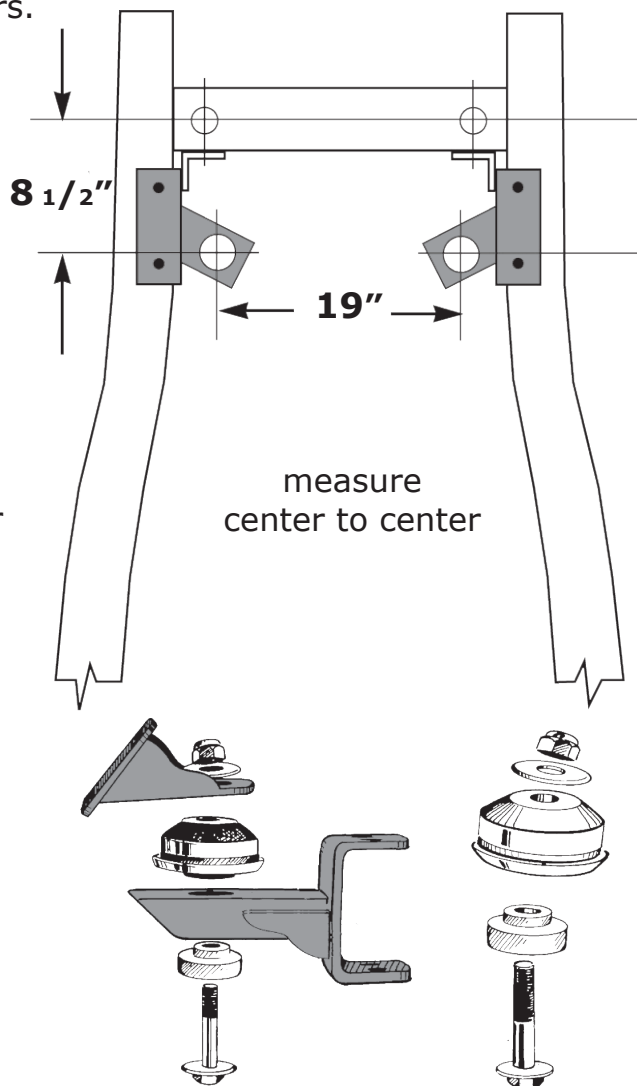

4 Install all bolts and tighten. Install CE engine mounts on engine in place of original factory mounts. Install rubber cushion set as shown.

5 Bolt transmission spacer to transmission rubber mount. Spacer moves mount holes back 1 1/2 inch.

5 Install X-member kit by following its directions.

5 Engine and transmission can now be installed and bolted into place.

Note: Oil filter will need an adapter to clear frame without cutting.