



CP-2212G

1941-48 Ford Car Small Block Ford V8 (1965+) Engine Mount Kit for use with Chassis ENgineering Bolt-on Pinto Mustang IFS

1 Install new CE Pinto-Mustang IFS crossmember first using the installation instructions that came with the kit. If the original steering bracket has not been removed yet, do so now.

2 Fit frame adapters as required to specifications shown. Remove any rivet heads that interfere with placement (grind level with frame).

Note: This kit is intended only for use with CE Pinto Mustang Bolt-on IFS

3 Make sure mounts are straight, level and exactly 19 inch center to center. Doublecheck all measurements, drill mounting holes and install.

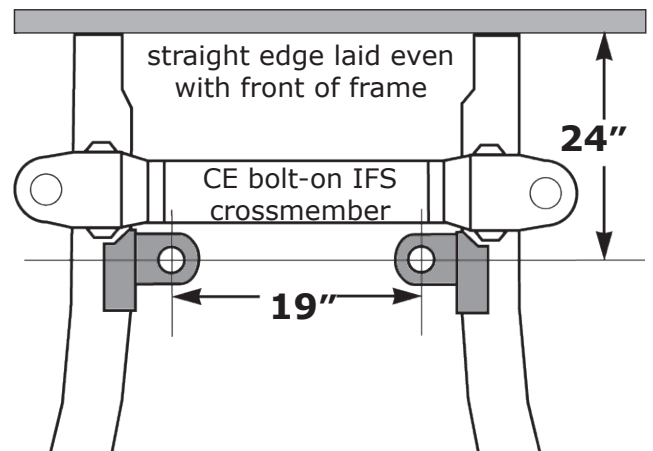

4 Bolt engine mounts to block and install engine. Installer is responsible for final fit. Generally the frame mounts will clear the IFS with no problems. Make sure to install the cushion set as shown.

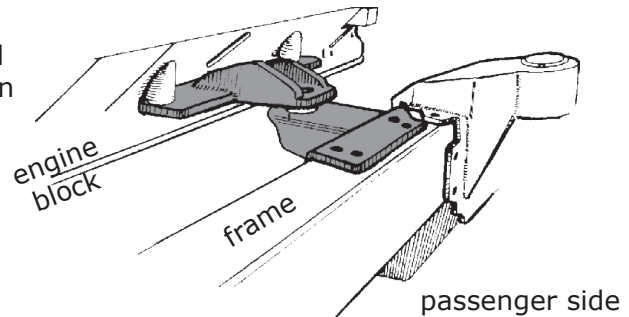
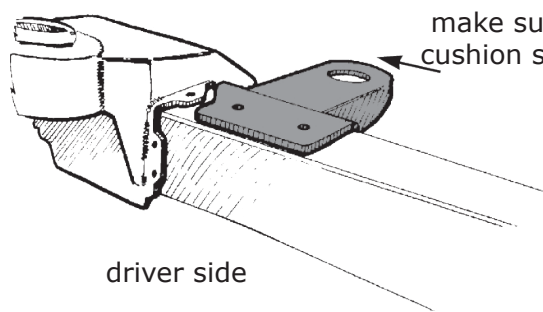

Note: engine mounts are both the same and both offset. This makes both sides equal when installed.

5 Drill bolt holes thru frame mounts. Install and tighten bolts. Note: top and bottom holes are different sizes. Access hole on inside of mount will match frame access holes in most cases, but frames can differ. Work with the bolt access your particular frame has.

The best clearance is given by using a Bronco-type oil pan. The original can be used as well, but will need to be notched for proper fitting.

