

CP-2204 ES-2230

1933-34 Ford 289-351 Windsor Small Block Ford V8 Engine Mount Kit (CP-2805 for 49-53 Ford & Mercury Flathead)

1 Position and tack weld both frame adapters in place as shown.

2 Double check measurements and weld adapters to frame. **Note:** Sometimes the boxing plates are already installed inside the frame channel instead of the outside. The frame mounts are extra length to accept this. In fact, if the boxing plates are correctly installed, the frame mounts will need to be shortened to match, or the engine mount holes can be slightly ovalled to allow for variation of width.

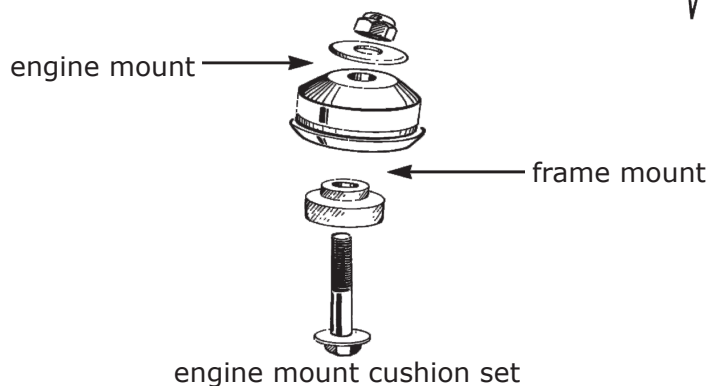
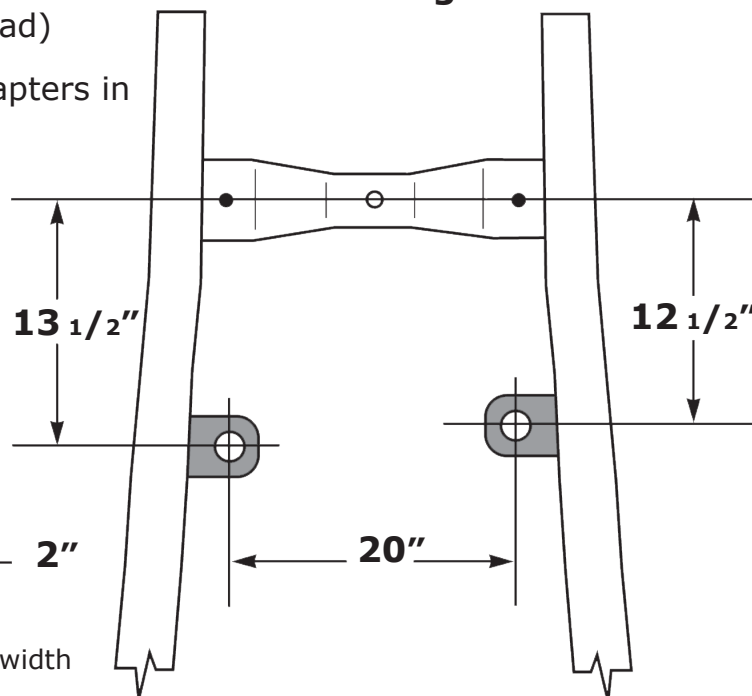

1933-34 Ford X-Member Modification & Transmission Mount Kit fits C4 Transmission

- 1** Remove original saddle from center of X-member. Be careful with rivet holes as some are reused.
- 2** Bottom lip on frame X-member will need to be straightened back to 90 degrees. Flatten dimples around old rivet holes.
- 3** Slide bottom plate and uprights into X-member from rear. Line up front holes on bottom plate with original rivet holes. Clamp into place and ream-drill all holes to 11/32 inch. Install bolts. Drill side brace holes to 11/32 inch and bolt to X.