

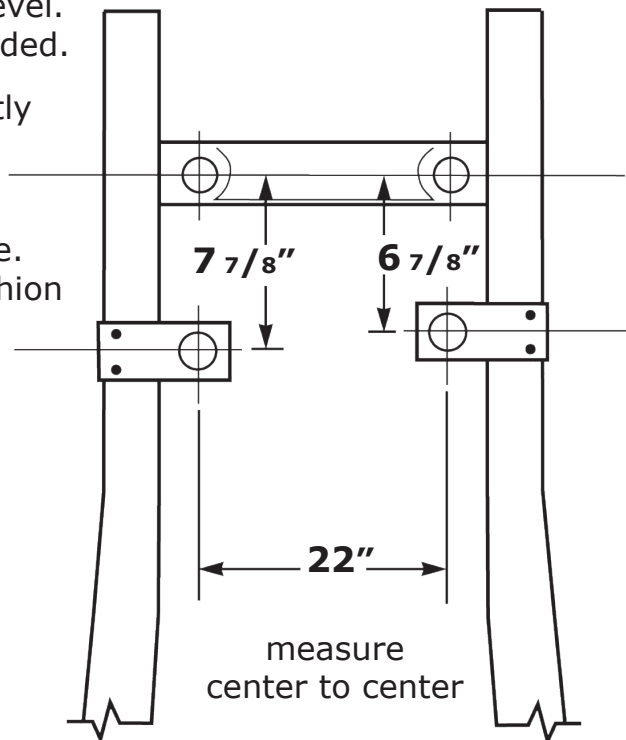

CP-2202

1941-48 Ford Car Small Block Ford V8 (1965+) Engine Mount Kit for use with original front crossmember

- 1** Place frame adapters around frame and clamp in position as shown. Adapters should be straight, level and centered.
- 2** Drill 3/8" holes in frame and fasten with 3/8 inch bolts. Be sure adapters remain straight and level. Notch for clearance around steering bracket if needed.
- 3** Once the mounts are straight, level and exactly 22 inch center to center, doublecheck all measurements and finally tighten bolts.
- 4** Bolt engine mounts to block and install engine. Installer is responsible for final fit. Install cushion set as shown.

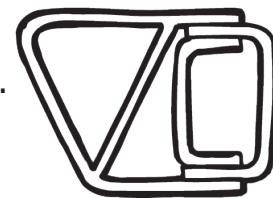

engine mount

frame adapter

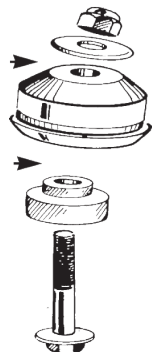

- 5** The car can now use matching Chassis Engineering components, such as transmission mount kits, without modification.

The best clearance is given by using a Bronco-type oil pan.

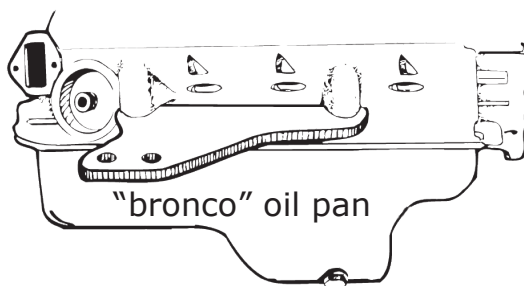

The original oil pan can be notched for clearance as well.

