



CP-2126 CP-2127

1941-48 Mercury Car Chevy Small Block V8 Engine Mount Kit

(note: for cross-steering use chevy R.H manifold - center dump lean back)

for use with Cross Steering (stock or CE adapter)

- 1 Remove original frame mounts (engine) from front crossmember.
- 2 Place frame adapters around frame and clamp into position shown. Make sure adapters are straight and level.

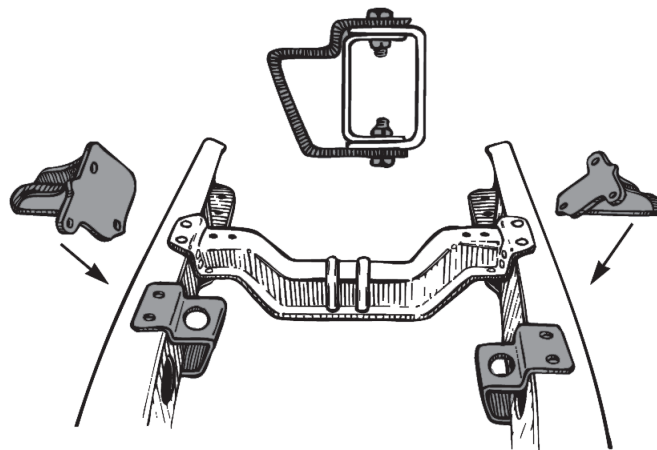
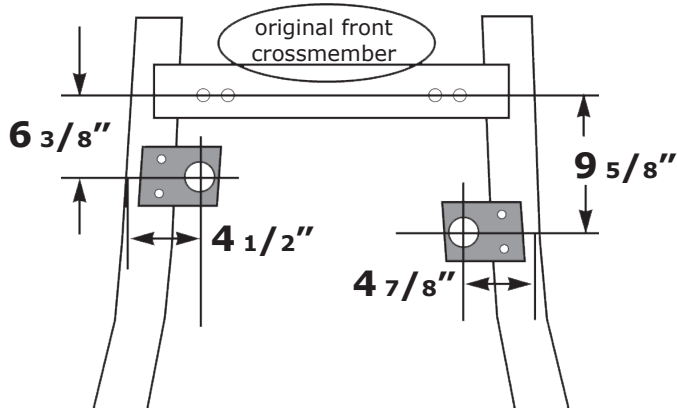

- 3 Drill bolt holes in frame to 3/8 inch. Install bolts and tighten.
- 4 Bolt offset engine mount to driver side of engine and standard mount on the passenger side. Install cushion set as shown below.

for use with Mustang II Independent Front Suspensions

- 1 Remove original steering mount from frame.
- 2 Place frame adapters around frame and clamp into position shown. Make sure adapters are straight and level.



note: exhaust manifold clearance can be had by using a 1968-69 Chevy

Right-hand manifold on the left side.

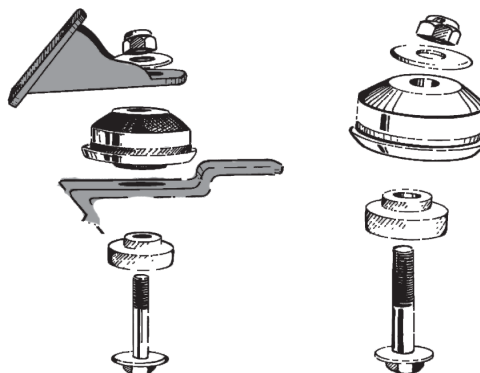
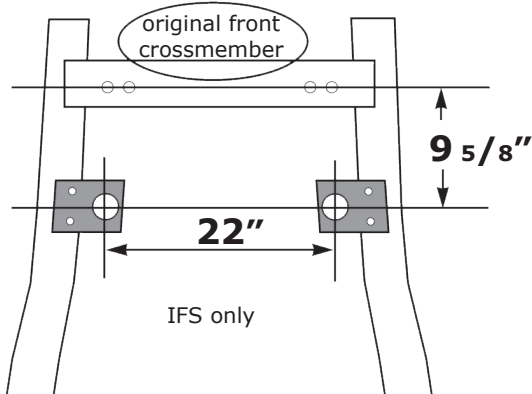

- 3 Drill bolt holes in frame to 3/8 inch. Install bolts and tighten.
- 4 Bolt engine mounts to engine. Install cushion set as shown below.