



CP-1100 ES-1121

CP-1102 ES-1123

(CP-) Small Block Chevy V8 Engine and (ES-) Transmission Mount Kit

CP-1100 : 1937-39 Chevy (Stock Steering/Pinto Mustang IFS)

CP-1102 : 1939 Chevy Deluxe & 1937-39 Chevy (CE Stock Steering)

Remove both original transmission crossmembers. Remove battery box and side splash aprons around engine. If so equipped, remove rear bolt from shock absorbers (solid axle models), then grind rivet heads between shock bolts flush with frame. Bolts can be reinstalled later.

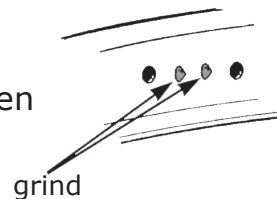

1 Install frame adapters over frame and position as shown. Note differences in driver/passenger side mounting. Only cross steering and 1939 Chevy Deluxe models require an offset mount on the driver side, the rest do not.

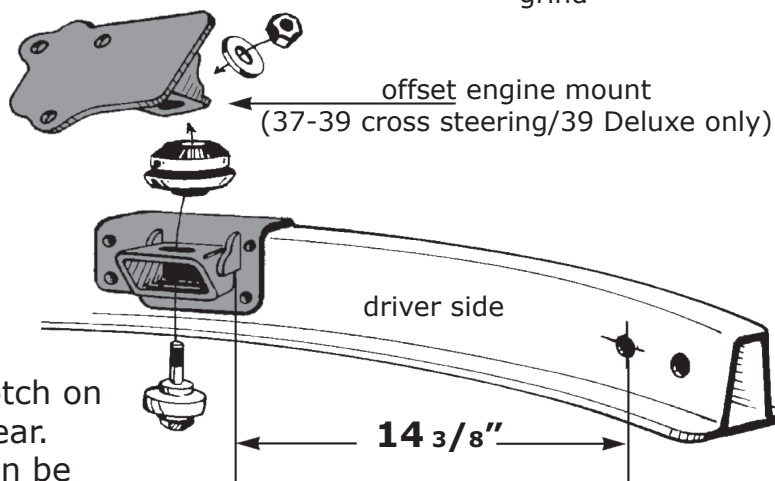

2 Clamp adapters in place on frame and drill necessary 5/16 inch holes.
39 Deluxe only: install adapter with notch on driver side. Notch fits around steering gear. Bolt in place. If desired, frame mount can be welded, but this is not required.

ES-1121 Transmission Mount Kit

1 Place reinforcing plate over frame and tap into place.

2 Running board flanges may be trimmed for clearance if needed.

3 Reinforcement plate will bolt to frame in this position. We recommend checking fit with engine and transmission in place before finalizing mounts.

Support car safely with stands.

4 When sure of spacing, drill all eight 3/8 inch holes through the inside of the frame. If installing with body on frame, outer holes can be tricky to center. Use a sharp center punch thru inner frame to mark outer side. The dimple in outer frame can then be checked for correct placement. If not correct, punch new dimple using mark as locating aid. When located properly, drill thru frame from inside out. Bolt or weld crossmember in place. Do not tighten to excess, this frame isn't strong.

