

# AT-2036

## 1935-40 Ford Replacement X-Member Kit (note: recommended for experienced builders)

**1** Check frame rails for true or out of square condition and correct any problems found. Remove X member. Note: at this point, the outer rails should be tied down in a jig or fixture. Frame lips will need to be straightened to 90 degrees. Flatten dimples around old rivet holes.

**2** Position according to the dimensions and tack weld both X-rails into frame as shown.

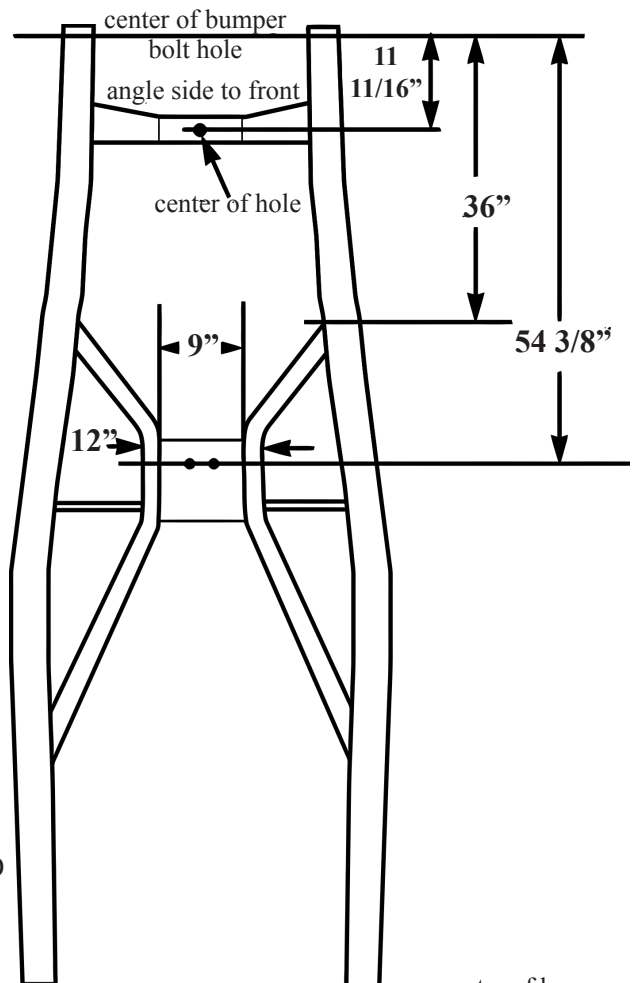
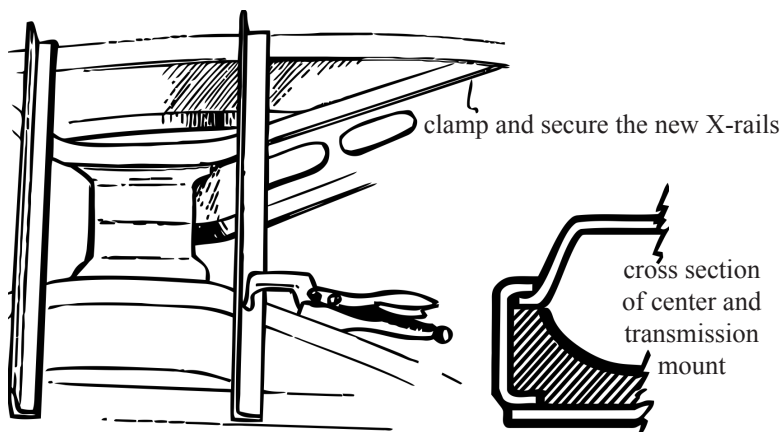

**3** Double check measurements and place center transmission mount. Tack weld the top wing and inside plates first.

**4** Clamp bottom plate in place and line up to dimensions. Once in place, center punch all holes.

**5** Recheck all dimensions again before finish welding all joints.

**6** Install bottom transmission plate. Place plate over center punched marks and drill holes to 11/32 inch. Install bolts and fasten to X. Turbo 350 transmissions will use the holes given. Different transmissions may require custom fitting. Use Turbo 350 transmission cushions only.

